

# AC2 Wind Tunnel Model

Adrian DOBRE

INCAS - National Institute for Aerospace Research “Elie Carafoli”  
Bd. Iuliu Maniu 220, Bucharest 061136, Romania  
adobre@incas.ro  
DOI: 10.13111/2066-8201.2010.2.2.17

***Abstract:** CESAR focuses on small-size commercial aircraft providing manufacturers with an enhanced ability needed to become fully competitive in the world market. The objective is to build up a new development concept for this aircraft category and to improve selected technologies enabling a significant reduction of the time-to-market and lowering the overall development, operation and maintenance costs, while considering safety, passenger comfort and environmental impact. The CESAR aspires to provide technologies and knowledge for advanced wing, competitive and environmentally acceptable propulsion unit and new technologies for selected aircraft systems to reduce aircraft operating costs and improve safety.*

## 1. WIND TUNNEL MODEL

The AC2 model was built within the CESAR project according to the geometric and aerodynamic specifications for the CESAR Aircraft 2 turbulent wing and high lift devices.

The AC2 model is designed to collect data for the operative envelope of the aircraft (for a clean configuration) in the INCAS trisonic wind tunnel.

## 2. MODEL DESCRIPTION

The model scale was established at  $k_s = 0.06$ . The AC2 model is designed for measurements of aerodynamic forces and moments by using the 2.00 MK XXVI TASK six components internal strain gauge balance. The AC2 model is built in a modular design that allows easy installation in INCAS trisonic wind tunnel on an existing U-shaped sting of a lenticular cross section. The sting is shown in figure 1 below:

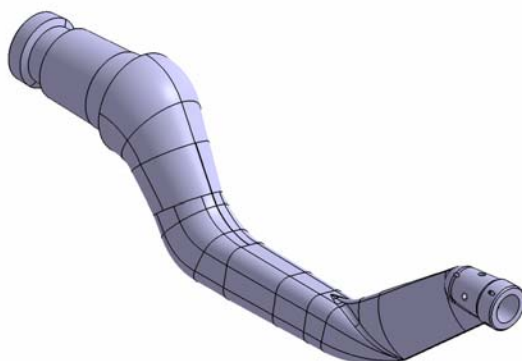

Figure 1

The model fuselage is divided into three sections, as follows:

- forward fuselage with the length  $L1 = 220$  mm
- central fuselage with the length  $L2 = 234$  mm, containing the TASK internal balance
- rear fuselage.

The balance center is located at 350.958 mm from the nose of the model.

Two flat surfaces were provided on the central fuselage, the first one for alignment of the model in the wind tunnel by means of an inclinometer and the second one for the attachment of the model wing.

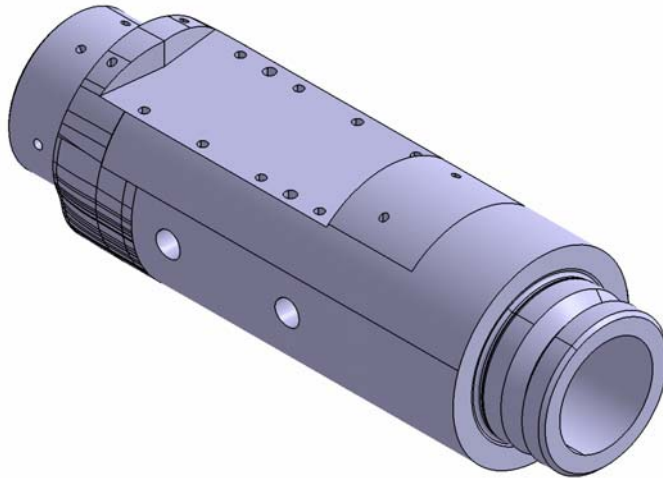

Figure 2 - Central fuselage of AC 2 model

Due to the configuration of the sting at its front, (see Fig. 1), it was not possible to comply with the requirement of positioning the balance center at 30% of the wing CMA and to provide at the same time the 4 mm gap needed between the rear fuselage and the sting in order to allow its deformation under aerodynamic loads without touching the inside of the model. This would have led to excessive thinning of the rear fuselage area near the front end of the sting where the TASK balance is mounted. The attachment of the empennage on the dorsal side of the rear fuselage would also become more difficult.

The lenticular U-shape of the sting requires the manufacturing of the rear fuselage in two halves attached to the central fuselage by two screws M5x10 and a dowel pin  $\phi 5 \times 12$ . The two halves are attached to one another by four screws M5x16, STAS 5144-80.

Locating the balance at 30% of the wing CMA would create significant difficulties in assembling the two rear semi fuselages together and to the central fuselage, and also an unacceptable displacement of the lenticular hole for the sting exit near the model tail.

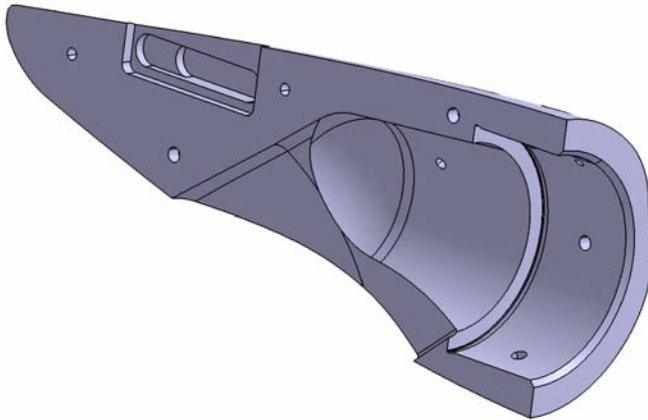

Figure 3 - Rear left semi fuselage

The balance center is located at ~ 0% of the wing CMA. The coordinates of this point to 25% of the wing model CMA are:

X = 377.933 mm from the nose of the model

Y = 166.922 mm

Z = - 45.613 under the center line of the model

#### **Wing Plan form**

The following wing plan form parameters must be considered:

Wing Span: 798.78 mm

Wing Area (Reference Area): 0.0792 m<sup>2</sup>

Aspect Ratio: 8.05

Taper Ratio: 0.370

Sweep Angle (@ 25% Chord): 16.686 °

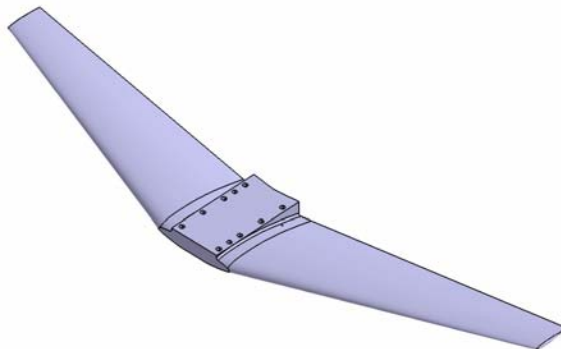

Figure 4 - View from above

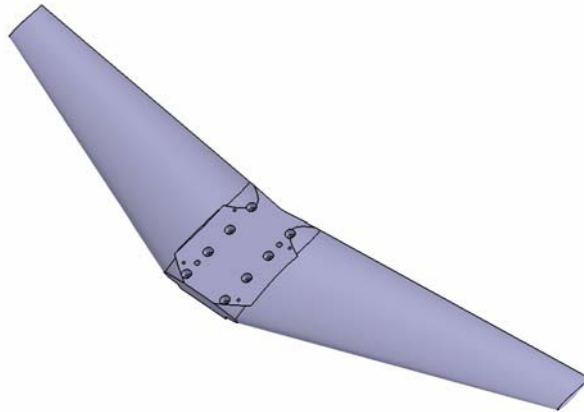

Figure 5 - View from below

The position of the TASK balance was established according to the existing dimensions on the standard 2D drawing "SOCAT - Preliminary release" at 30% of the wing CMA, without checking whether or not the 3D geometry of the airplane corresponds to the standard drawing received with the 3D geometry of the plane "AC2.igs Plane", in terms of wing and horizontal and vertical empennage positions on the plane.

Only the wing span and empennage span, the length and diameter of the fuselage, the wing root, wing tip and empennage root and tip chords were checked, and they corresponded to the dimensions in the standard 2D drawing. Hence it was concluded that the 3D geometry corresponds to the standard drawing.

When the final 3D geometry was received, it was compared with the 3D geometry received with the standard "SOCAT" drawing. It was found that the airplane wing position in the two 3D geometries was the same, and so were the span and root and tip wing chords. Hence it was concluded that the balance position according to the standard drawing was correct and it was preserved for the last 3D geometry.

However,, when the CMA wing position and points at 25% and 30% of wing CMA were drawn, the wing was found to be positioned 521.13 mm further forward (i.e. 32.146 mm at scale model) compared with the 3D geometry received.

As a result, it will be necessary to recompute the torsor of aerodynamic forces and moments acting on model from the point where the center of the TASK balance is located at the position of 25% wing CMA, or 30% wing CMA.

The position of the vertical and horizontal empennages was kept as in the airplane AC2 first 3D drawing received on 01.06.2009, the distance between the focus of the wing and horizontal empennage is 250.432 mm at scale model.

Model geometry complies with the 3D geometry received on 12/10/2009.

The model was manufactured at ROMAERO Baneasa in one and half months.



Pictures at ROMAERO Baneasa



AC2 model at the final plenum meeting in Prague, Czech Republic

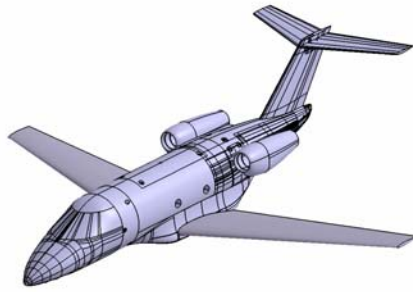

Isometric view of AC2 model

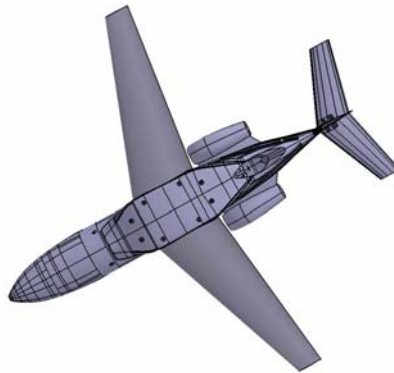

Bottom view of the model

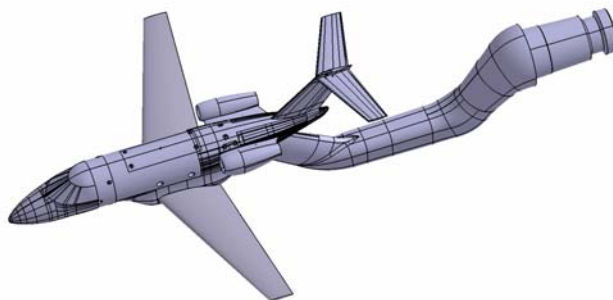

AC2 model and sting assembly

## REFERENCES

- [1] Didier Chartrain, “Report on wing design objectives for AC2, turbulent wing”, VZLU, Document Code: CE-SOCATA-T12 - D1.2.2-5, pp 5/7, 2008